

# Java™ Technology for the Wireless Industry (JSR-185)

---

Road Map 1 Definition

Java 2 Platform, Micro Edition

Date: 1/9/03 00:20:34



Sun Microsystems, Inc.  
4210 Network Circle  
Santa Clara, CA 95054  
1 (800) 786.7638  
1 (650) 960.1300

Copyright © 2003 Sun Microsystems, Inc., 4150 Network Circle, Santa Clara, California 95054, U.S.A. All rights reserved. U.S. Government Rights - Commercial software. Government users are subject to the Sun Microsystems, Inc. standard license agreement and applicable provisions of the FAR and its supplements.

Sun, Sun Microsystems, the Sun logo and Java are trademarks or registered trademarks of Sun Microsystems, Inc. in the U.S. and other countries.

Products covered by and information contained in this service manual are controlled by U.S. Export Control laws and may be subject to the export or import laws in other countries. Nuclear, missile, chemical biological weapons or nuclear maritime end uses or end users, whether direct or indirect, are strictly prohibited. Export or re-export to countries subject to U.S. embargo or to entities identified on U.S. export exclusion lists, including, but not limited to, the denied persons and specially designated nationals lists is strictly prohibited.

**DOCUMENTATION IS PROVIDED "AS IS" AND ALL EXPRESS OR IMPLIED CONDITIONS, REPRESENTATIONS AND WARRANTIES, INCLUDING ANY IMPLIED WARRANTY OF MERCHANTABILITY, FITNESS FOR A PARTICULAR PURPOSE OR NON-INFRINGEMENT, ARE DISCLAIMED, EXCEPT TO THE EXTENT THAT SUCH DISCLAIMERS ARE HELD TO BE LEGALLY INVALID.**

---

Copyright © 2003 Sun Microsystems, Inc., 4150 Network Circle, Santa Clara, California 95054, Etats-Unis. Tous droits réservés. Droits du gouvernement américain, utilisateurs gouvernementaux - logiciel commercial. Les utilisateurs gouvernementaux sont soumis au contrat de licence standard de Sun Microsystems, Inc., ainsi qu'aux dispositions en vigueur de la FAR [ (Federal Acquisition Regulations) et des suppléments à celles-ci.

Sun, Sun Microsystems, le logo Sun et Java sont des marques de fabrique ou des marques déposées de Sun Microsystems, Inc. aux Etats-Unis et dans d'autres pays.

Les produits qui font l'objet de ce manuel d'entretien et les informations qu'il contient sont régis par la législation américaine en matière de contrôle des exportations et peuvent être soumis au droit d'autres pays dans le domaine des exportations et importations. Les utilisations finales, ou utilisateurs finaux, pour des armes nucléaires, des missiles, des armes biologiques et chimiques ou du nucléaire maritime, directement ou indirectement, sont strictement interdites. Les exportations ou réexportations vers des pays sous embargo des États-Unis, ou vers des entités figurant sur les listes d'exclusion d'exportation américaines, y compris, mais de manière non exclusive, la liste de personnes qui font objet d'un ordre de ne pas participer, d'une façon directe ou indirecte, aux exportations des produits ou des services qui sont régi par la législation américaine en matière de contrôle des exportations ("U .S. Commerce Department's Table of Denial Orders "et la liste de ressortissants spécifiquement désignés (" U.S. Treasury Department of Specially Designated Nationals and Blocked Persons ")), sont rigoureusement interdites.

**LA DOCUMENTATION EST FOURNIE "EN L'ÉTAT" ET TOUTES AUTRES CONDITIONS, DECLARATIONS ET GARANTIES EXPRESSES OU TACITES SONT FORMELLEMENT EXCLUES, DANS LA MESURE AUTORISEE PAR LA LOI APPLICABLE, Y COMPRIS NOTAMMENT TOUTE GARANTIE IMPLICITE RELATIVE A LA QUALITE MARCHANDE, A L'APTITUDE A UNE UTILISATION PARTICULIERE OU A L'ABSENCE DE CONTREFAÇON.**



Please  
Recycle



# Table of Contents

---

Introduction.....	4
About this Document.....	6
Road Map Fundamentals.....	7
Release 1.....	10
Calendar of Candidate JSRs.....	14

# Introduction

---

The Java Community Process<sup>SM</sup> (JCP<sup>SM</sup>) provides a broad set of distinct technologies in the form of Java<sup>TM</sup> Specification Requests (JSRs) that can be combined to make various meaningful deployments of Java platforms. The Mobile Information Device Profile (MIDP) plus the Connected, Limited Device Configuration (CLDC) is the ideal platform for mobile phones.

JSR-185 will address these questions:

- Given the potential number of optional JSRs that might be associated with MIDP, how can we ensure that each is architecturally coherent with the other pieces in a handset?
- How can content developers and operators know when new APIs will be available in real deployments, so they can take advantage of them?
- When would a product manager be able to rely on those APIs to define them as features in new devices?

JSR-185 has three high-level deliverables:

- A road map of mobile phone-related JSRs and a description of their availability in different markets around the world.
- A specification describing the essential client components of an end-to-end mobile phone environment and the recommended combinations of Java 2 Platform, Micro Edition (J2ME<sup>TM</sup>) technologies. JSR-185 will specify requirements that work to enhance end-to-end compatibility.
- An integrated Reference Implementation (RI) and Technology Compatibility Kit (TCK) for the technologies described in the specification.

This document is the first road map for mobile phone JSRs. JSR-185 will specify a predictable platform for application developers, and a deliverable set of targets for device manufacturers. In addition, there is a section which provides some rationale for the basic decision making process, and some criteria for JSR consideration.

At present, the wireless community is migrating towards a standard platform for Java technology-enabled devices. The JSRs that will be supported on this platform are:

- JSR-30 CLDC 1.0
- JSR-37 MIDP 1.0
- JSR-120 WMA

JSR-185 is intended to create a community-driven process that is more precisely defined and to move it forward as the industry continues to expand the capabilities and resources of mobile phones.

The JSR-185 expert group spans a wide variety of companies listed here in alphabetical order:

- 4thPass
- Aplix Corporation
- JAMDAT Mobile Inc.
- Matsushita
- Motorola
- Nokia
- NTT DoCoMo
- Orange PCS
- Research In Motion
- Samsung
- Siemens
- Sony Ericsson
- Sprint
- Sun Microsystems, Inc.
- Symbian, Ltd.
- T-Mobil
- Telefonica Moviles Espana
- Vodafone

These experts are drawn from nine countries on three continents, and represent three distinct fields in the wireless device space: wireless carriers, software vendors, and device manufacturers.

This road map is a summary of the expressed and derived needs of software vendors and wireless carriers, tempered by the practical input from the device manufacturers. A key goal of JSR-185 is to minimize API fragmentation in the mobile phone device market.

# About this Document

---

## Definitions

This document uses definitions based upon those specified in RFC 2119. For more information on these terms and definitions, see <http://www.ietf.org>.

Term	Definition
<b>MUST</b>	The associated definition is an absolute requirement of this specification.
<b>MUST NOT</b>	The definition is an absolute prohibition of this specification.
<b>SHOULD</b>	Indicates a recommended practice. There may exist valid reasons in particular circumstances to ignore this recommendation, but the full implications must be understood and carefully weighed before choosing a different course.
<b>SHOULD NOT</b>	Indicates a non-recommended practice. There may exist valid reasons in particular circumstances when the particular behavior is acceptable or even useful, but the full implications should be understood and the case carefully weighed before implementing any behavior described with this label.
<b>MAY</b>	Indicates that an item is truly optional.

## Dates

<b>Specification Available</b>	The availability of the specification and related materials (RI, TCK, and applicable implementation guides)
<b>Commercial Products Available</b>	The expected initial commercial availability of devices based on the specification.

## References

J2ME™ Connected Limited Device Configuration Specification 1.0a  
(<http://jcp.org/aboutJava/communityprocess/final/jsr030/index.html>)

Mobile Information Device Profile Specification 2.0  
(<http://jcp.org/aboutJava/communityprocess/first/jsr118/index.html>)

Java™ Wireless Messaging API Specification 1.0  
(<http://jcp.org/aboutJava/communityprocess/final/jsr120/index.html>)

Mobile Media API Specification 1.0  
(<http://jcp.org/aboutJava/communityprocess/final/jsr135/index.html>)

Connected Limited Device Configuration Public Review Draft Specification 1.1  
(<http://jcp.org/aboutJava/communityprocess/review/jsr139/index.html>)

# Road Map Fundamentals

---

## About Road Maps

This document (Road Map 1) is the first in a series of road maps expected to be issued at six- to nine-month intervals. These road maps will provide an outline of common functionality that software developers can expect in Java Technology for the Wireless Industry (JTWI)-compliant devices. Future road maps will describe additional functionality consistent with the evolution of mobile phones. In order to be identified in any of these road maps, APIs must be commercially available at the road map milestone.

---

## Technology Categories

JSR-185 defines two categories of JSRs: mandatory and conditionally required.

**Mandatory** means that the device **must** pass the TCK for the mandatory JSR for it to be JTWI-compliant. JSR-185 **may** impose additional constraints on the JSR to ensure interoperability and compatibility. The features exposed through a mandatory JSR will be commonly found on mobile phones.

**Conditionally required** means that if a device contains a capability referenced by the JSR and exposes that functionality to Java applications, JSR-185 mandates the device **must** pass the TCK of this JSR. JSR-185 may choose to impose additional constraints on the JSR to ensure interoperability and compatibility. The expert group strongly recommends that mobile phones implement the conditional JSRs.

**Other JSRs:** JSRs not mentioned in the road map may still be applicable for many applications and could appear in mobile phones, and this expert group does not discourage their use. JSR-185 imposes an important constraint on compatible implementations to minimize fragmentation. A device may choose to expose a feature that can be used by a Java technology-based application. If there is a related, complete J2ME JSR that supplies an API for the feature, then the device **must** pass the JSR's TCK. Although Licensee Open Classes may also be supplied for backwards compatibility, this practice is discouraged, and the APIs should be removed as soon as practical. Likewise, Licensee Open Classes should be removed from Software Development Kits (SDKs) to encourage developers to migrate as quickly. Licensee Open Classes should be marked as deprecated once the corresponding standard API is available.

---

## Criteria for JSR Inclusion

Future releases of this road map (and the corresponding specification) will expand the available technologies. Although all JSRs will require careful review by the expert group, the following criteria can be considered a first tier of requirements before the JSR can be considered as possible.

- Time (Availability)

For a JSR to be considered, it must be scheduled to be final prior to the public review of the JSR-185 specification.

- Footprint

Although there is no specific requirement, footprint is a critical factor in choosing appropriate JSRs for this specification. Appropriate JSRs make reasonable trade offs between functionality and the practical size of implementation.

- Applicability

Only JSRs which are meaningful in mobile phones are considered. Many JSRs have broader applicability; these are particularly well suited for consideration as those specifications may merit appropriate clarifications to make them highly suited to mobile phones.

- Commercial Product Availability

A key consideration for application developers is that the API is readily available in mobile phones. Candidates for the road map are expected to appear in commercially available products as specified in the road map summary.

- Licensing

JSRs for consideration must be made available to licensees on fair and reasonable terms.



## CHAPTER 2

# Release 1

---

The first release of the JSR-185 road map will leverage industry momentum of the wireless community to migrate towards a standard platform for mobile phones. The road map and the following specifications for Release 1 will unify the variations in the core functions found in an expanding number of Java technology-enabled devices on the market today.

---

## Summary

Specification Available:	March, 2003
Commercial Products Available:	Q2/Q3, 2003

### Mandatory JSRs

JSR-30 CLDC 1.0

JSR-120 WMA

JSR-118 MIDP 2.0

### Conditionally Required JSRs

JSR-135 MMAPI

JSR-139 CLDC 1.1

# Mandatory JSRs

## JSR-30 CLDC 1.0

JSR-30 **must** be present in a JTWI-compliant device unless it is superseded by JSR-139.

### Rationale

CLDC 1.0 is the foundation for the profile. It provides basic API services, and the VM itself. At this point, CLDC 1.1 is not required to deliver the overall platform goals and therefore not part of the required JSRs.

### Use case

As this is the core of the platform, all applications will depend on elements of CLDC 1.0 (or 1.1).

## JSR-118 MIDP 2.0

JSR-118 **must** be present in JTWI-compliant devices.

### Rationale

MIDP 2.0 offers a carefully selected set of additional APIs beyond what exists in MIDP 1.0. These APIs address a variety of issues for MIDP 1.0, including:

- Improved gaming services
- Audio extensions
- Security extensions
- Network extensions
- Secure networking
- Improved high-level user interface support

In addition MIDP 2.0 substantially clarifies the MIDP specification, making interoperability more practical. Some of the added APIs are present to make higher performance applications possible.

The status of the optional functions of JSR-118 will be reviewed and some functions made mandatory for use with JSR-185 to decrease differences between implementations that impact application interoperability and portability. Security elements will be required, but may be dependent on underlying technology.

### Use Case: Single-Player Game

Typical games will be turn-based or puzzle-oriented games. Advanced games will be based on continuous action and motion and audio effects. Applications could store and retrieve local data as well as store and retrieve from a remote server. Remote data could include high scores, new scenarios, etc.

## JSR-120 WMA

JSR-120 **must** be present in JTWI-compliant devices.

### Rationale

Wireless messaging is a key service that can be used by games, business applications and commerce applications. Wireless messaging provides simple and low-cost mechanism to enable application communications.

Although some WMA implementations may use a specific underlying messaging technology such as Short Message Service (SMS), the JSR-120 specification does not mandate any explicit approach. As a result, devices can support this API using other readily available underlying network protocols.

"Push" capabilities, which will be described in a future recommended practices document for this JSR, will be a mandatory element of the JSR-185 specification.

The specification of JSR-185 will include full end-to-end tests as part of its specification to ensure interoperability.

### Use Case: Multi-Player Game

Multi-player games will typically use an intermediate server to manage game state and coordinate players. Some multi-player games will communicate directly using WMA or a combination of both.

### Use Case: Work Flow/Approval Tool

An application for use in an enterprise which allows users to review, approve and forward work flow items. Web services can simplify the creation of applications. HTTP and wireless messaging can provide data transport.

# Conditionally Required JSRs

## JSR-135 MMAPI

JSR-135 **must** be present in JTWI-compliant devices if they expose video playback, audio, or video/image recording capabilities to Java applications.

### Rationale

This JSR provides for rich user interface features, more compelling games, and new types of content. Part of JSR-185's specification will include specific media types that must be supported so that content providers and application developers can depend on a known set of content types.

### Use Case: Advanced multi-media game

Advanced multi-media games will be continuous action/motion-based games such as driving simulators and combat games. These games provide substantial visual feedback in the form of video clips and will typically have continuous, rather than turn-based, play. Audio enhancements such as music and sounds will also be common. Audio enhancement of more conventional games is also a common use of multi-media services.

### Use Case: Karaoke Music Player

A music player which provides a mechanism to interact with the device as a Karaoke is another type of application of JSR-135.

## JSR-139 CLDC 1.1

JSR-139 **may** be present in JTWI-compliant devices. If present, it supersedes JSR-30.

### Rationale

CLDC 1.1 includes benefits to the platform with minimum additional overhead. In addition to floating point, it includes weak references (valuable in memory constrained environments), improved date handling, plus minor additions and clarifications. It is likely to become mandatory in subsequent releases of this specification.

### Use case

CLDC 1.1 is an alternative to using CLDC 1.0 in this release of the road map.

## CHAPTER 3

# Calendar of Candidate JSRs

Road map 1, as described in this document, is the first step in the progression of this JSR. This calendar shows some of the JSRs which are under consideration for inclusion in R2 and future JSR-185 road maps.

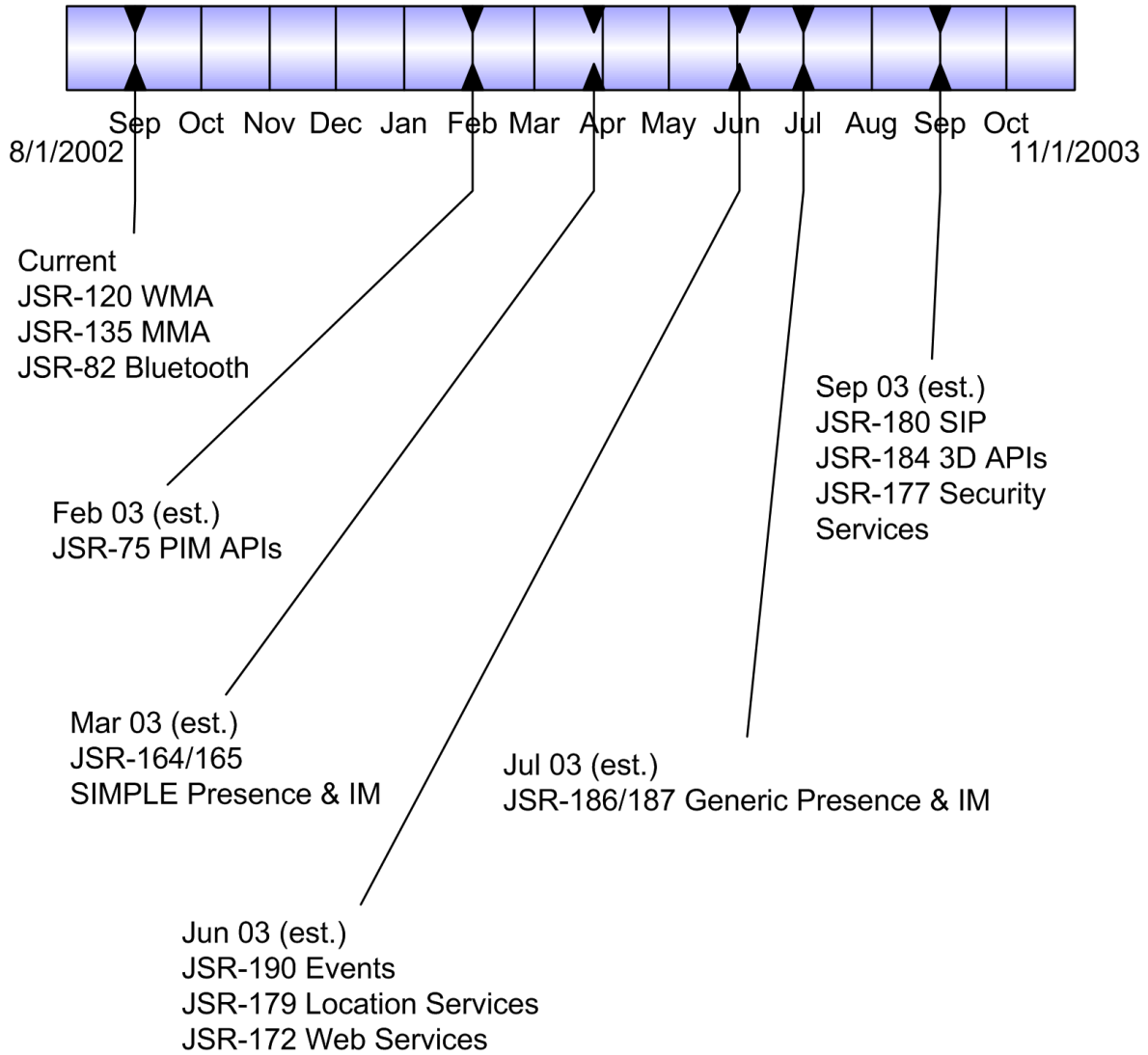



Sun Microsystems, Inc.  
4210 Network Circle  
Santa Clara, CA 95054

1 (800) 786.7638

1 (512) 434.1511

Sun: [www.sun.com](http://www.sun.com)

Java: [java.sun.com](http://java.sun.com)